

Service Manual

Dishwasher

ADP 941/1 WH

Model Version		Page
	ADP 941/1 WH	
	8542 941 10110	
	Technical data	2 - 4
	Spare part list	5 - 6
	Exploded view	7 - 8
	Circuit diagram	9
	Program diagram	10
	Text/Legend	11 - 19
	Family	Global A4

Technical data**Dimension**

Height	82,0-87,0	cm
Width	59,5	cm
Depth	57,0	cm
Weight	~ 55	kg

Decor plate

Thicknes max.	4	mm
Width	584	mm
Height	595	mm
Weight max.	1,8	kg

Specification (normal program)

Capacity	12	standard setting pl.
Water consumption	22	l
Energy consumption	1,5	kWh
Program time	~ 82	min
Noise level	52	db (A)
Detergent consumption	25	ml
Salt consumption by 21° dh	<20	g
Hot water connect. up to	60	°C

Alarms

Refill rinse aid
Refill salt
Water leakage

Program information

Start indicator
Net indicator

Volume (normal)

Water	Volume	Level
Regeneration	0,3 l	15 mm
Back rinse 3x	1,0 l	68 mm
Prewash	5,0 l	125 mm
Main wash	6,0 l	129 mm
Intermediate rinse 1	5,0 l	125 mm
Intermediate rinse 2	5,0 l	125 mm
Clear rinse	5,0 l	125 mm
Safety / overflow	8,5 l	141 mm

Measuring the level

Remove the coarse sieve, put in a measuring meter into the sump, measure the hight of the water level.

Detergent max.

Pre-wash	10	cm ³
Main-wash	45	cm ³
Rinse aid	125	cm ³
6 Dosage steps	1 - 6	cm ³

Water softener

Saltcontainer	2	kg
Resin container	900	cm ³
Regeneration dosage	300	cm ³

Water pressure

Inlet pressure	0,3-10	bar
Spray pump pressure	0,4	bar

Rotations

Spray pump motor	2800	RPM
Drain pump motor	2800	RPM
Spray arm lower	~ 30	RPM
Spray arm upper	~ 35	RPM
Ceiling rotor	~ 60	RPM

Flow rates / Inlet volume

Flow meter (at 0,3 bar = quantity 1,1 l/min)	208	Imp/l
Spray pump	~ 70	l/min
Drain pump	16	l/min
Pump height max.	1,3	m
Inlet valve	4,5	l/min
Valve for sieve	8	l/min
Spray arm lower	33	l/min
Sprayarm upper	30	l/min
Ceiling rotor / shower	8	l/min

Water distribution

Fine sieve	100	%
Self cleaning micro filter	~ 32	%

Electrical data**Base data**

Voltage	230	V
Frequency	50	Hz
Total power	2,0-2,2	kW
Fuse	10	A

Technical data

Motor

Spray pump motor

Voltage	220/230	V
Power consumption	~190	W
HI	69	Ω
HA	36,2	Ω
Capacitor	4	μ F

Drain pump motor

Voltage	220/240	V
Resistance	146	Ω

Heating

1 Element system

Voltage	220	V
Power consumption	1800	W
Resistance	12,1-13,4	Ω
Heating speed	~ 2,5	$^{\circ}$ C/min
Temperature on surface	~ 115	$^{\circ}$ C
Double safety thermostat self reset	85	$^{\circ}$ C

Potentiometer

Position 0	2,0	k Ω
Position 1	4,3	k Ω
Position 2	9,0	k Ω
Position 3	13,3	k Ω
Position 4	17,5	k Ω
Position 5	22,2	k Ω
Position 6	24,2	k Ω

Water valves

Single valve at inlet hose

Voltage	220/240	V
Frequency	50/60	Hz
Resistance	3,67	k Ω

Regenerating valve

Voltage	220/240	V
Frequency	50/60	Hz
Resistance	3,13	k Ω

Valve for sieve

Voltage	220/240	V
Frequency	50/60	Hz
Resistance	3,83	k Ω

Coil of dispenser

Voltage	220/240	V
Frequency	50/60	Hz
Resistance	1,43	k Ω

Relay

Heating relay

Voltage	220/240	V
Frequency	50/60	Hz
Resistance	5,5	k Ω

Reedcontact

flow meter
salt control
rinse aid control

NTC

15 $^{\circ}$ C	75	k Ω
20 $^{\circ}$ C	62	k Ω
30 $^{\circ}$ C	43	k Ω
40 $^{\circ}$ C	28	k Ω
50 $^{\circ}$ C	19	k Ω
60 $^{\circ}$ C	13	k Ω
70 $^{\circ}$ C	9	k Ω
80 $^{\circ}$ C	6	k Ω
85 $^{\circ}$ C	5	k Ω

Technical data

Regeneration

Volume	300	cm ³
Position 0 after wash cycles water hardness	-- 0-5 0-0,9 0-9	°dh mmol/l °Fh
Position 1 after wash cycles water hardness	6-8 6-10 1-1,8 10-18	°dh mmol/l °Fh
Position 2 after wash cycles water hardness	5-6 11-15 1,9-2,7 19-27	°dh mmol/l °Fh
Position 3 after wash cycles water hardness	4 16-21 2,8-3,7 28.37	°dh mmol/l °Fh
Position 4 after wash cycles water hardness	3 22-28 3,8-5,0 38-50	°dh mmol/l °Fh
Position 5 after wash cycles water hardness	2 29-35 5,1-6,3 51-63	°dh mmol/l °Fh
Position 6 after wash cycles water hardness	1 36-60 6,4-10,7 64-107	°dh mmol/l °Fh
Salt consumption for regeneration	77	g
Number of cycles with 2 kg salt	26	

Spare part list

Model **ADP 941/1 WH**
Service No. **854294110110**
Version **854294110110**

Pos. No.	12NC Code	Description
003 0	4812 440 19382	Traverse
004 0	4812 440 18952	Drip tray assy
004 1	4812 401 18402	Holder
011 0	4812 505 18357	Foot short
022 0	4812 440 18951	Side panel left
022 1	4812 440 18949	Side panel right
022 2	4812 440 18953	Spacer
024 0	4812 440 19401	Panel, rear
030 0	4812 310 18303	Table top WH
034 0	4812 404 78237	Spacer
034 1	4812 404 78236	Fastener
040 1	4812 417 18774	Hinge left
040 2	4812 417 18773	Hinge right
044 0	4812 492 38358	Spring f.door
044 1	4812 492 38364	Spring f.cap
047 0	4812 404 48591	Brake f.door
047 1	4812 401 18397	Band,brake
047 2	4812 404 68023	Hook
053 0	4812 440 88107	Plinth WH
061 0	4812 466 88461	Counter weight
103 0	4812 440 18978	Door outer
120 0	4812 440 18961	Door,inner
120 1	4812 440 18955	Batten
130 0	4812 417 58361	Tilt lock
131 0	4812 401 18416	Hook lock
191 0	4812 466 68534	Gasket door
192 0	4812 466 68467	Gasket, door lower
200 0	4812 418 18175	Container
241 0	4812 458 18276	Basket upper straight
241 1	4812 458 18324	Holder cups righth white
241 3	4819 528 88065	Wheel,basket upper
241 8	4812 466 68482	Spacer cap set
242 0	4812 458 18274	Basket lower cpl.
242 1	4812 528 88069	Wheel,basket lower
242 2	4812 458 18262	Plate,support f.basket lower
242 3	4812 458 18275	Plate,support f.basket lower
243 0	4812 458 18272	Basket cutlery
261 0	4819 462 38271	Rail telescope, inner
261 1	4819 404 48819	Cap rail
261 2	4812 462 78995	Cap rail ahead
263 0	4819 520 18013	Ball cage cpl.
263 1	4812 520 48001	Ball Niro 8 D
265 0	4812 404 48599	Basket adjustm. cpl.
265 2	4812 404 48589	Grip basket adjustment
301 0	4812 453 79538	Control panel WH
303 1	4812 417 58364	Child-prooflock cpl. WH
305 0	4812 440 18964	Batten WH
322 0	4812 453 79866	Insert panel WH
331 0	4812 413 58864	Knob program cpl. WH
332 0	4812 410 28528	Push button cap WH
350 0	4812 276 58037	Display board (DB)
351 1	4812 381 28021	Guide,light
400 0	4812 361 58119	Motor + spraypump cpl.220/240V
405 0	4812 360 18358	Spray pump
405 1	4819 515 28158	Gasket

Pos. No.	12NC Code	Description
420 0	4812 121 18132	Capacitor
421 0	4812 121 18156	Interf.filter
430 0	4812 360 18357	Pump,draining
430 1	4812 466 68506	Ring,sealing
450 0	4812 259 28657	Heating element
480 0	4812 321 28364	Cable harness set
480 1	4812 321 28371	Cable
480 3	4812 401 18418	Protector f.wiring
480 4	4812 401 18419	Cover of cable
490 0	4819 321 18136	Cable,mains 2m
490 1	4812 321 28367	Strain relief
521 0	4812 214 78171	Control board (CB)
531 0	4812 273 18054	Switch waterhardness
531 1	4812 273 18053	Wheel,fingertip
571 0	4812 281 28365	Valve inlet
571 2	4812 281 28362	Sieve valve
575 0	4812 281 28361	Regen.valve
583 0	4812 271 28355	Switch diaphragm
612 0	4812 280 58025	Relay heating
616 0	4812 281 18047	Contact,reed salt
616 1	4812 271 58161	Contact,reed rinsing agent
620 0	4812 218 38033	User board (UB)
623 0	4812 271 38356	Microswitch
633 0	4812 271 38355	Microswitch
680 0	4812 418 68133	Combidosage
680 1	4812 466 68495	Gasket
681 1	4812 466 68497	Gasket
681 2	4812 440 18975	Flap
682 0	4812 466 68496	Gasket
691 0	4812 282 68012	Feeler NTC
701 0	4812 530 28081	Hose, inlet 3/8Z cpl. 5m
701 0	4812 530 28082	Hose, inlet 3/8Z cpl. 3m
701 0	4819 530 28283	Hose, inlet 2m
701 1	4812 310 18302	Yoke
701 2	4822 480 50159	Sieve inlet
710 0	4812 418 68128	Monoblock
710 2	4819 310 38536	Nut threaded ring set
710 3	4819 466 69562	Gasket set
714 0	4812 462 78993	Threaded cap
714 2	4812 440 18963	Cabinet non-return flap
716 0	4812 418 68147	Reg.dosage
716 1	4812 466 68475	Gasket
716 2	4812 462 78994	Cover
721 0	4812 360 68043	Hub lower cpl.
721 1	4812 360 68047	Arm,spray lower cpl.
721 2	4812 466 68491	Gasket 25x2,3B
721 3	4812 466 68489	Gasket 76x2,5
721 4	4812 418 18176	Cabinet
722 0	4812 360 68044	Arm,spray upper
722 2	4812 360 68056	Hub upper straight cpl.
723 0	4812 360 68049	Arm,spray
723 1	4812 466 68483	Gasket
723 2	4812 404 48597	Clip,fix sprayarm
723 3	4812 505 18362	Connect,gaspipeline
726 0	4812 530 28786	Tube

Spare part list

Model ADP 941/1 WH
Service No. 854294110110
Version 854294110110

Pos. No.	12NC Code	Description
726 1	4812 530 28787	Tube
726 2	4812 505 18358	Nut
726 3	4812 466 68512	Gasket
726 4	4812 462 79633	Centering
743 0	4812 511 48171	Capacitor
743 1	4812 530 28102	Hose, inlet
743 3	4812 505 18364	Nut
743 4	4812 530 28807	Hose 9x1,5x270+10
743 7	4812 466 68514	Gasket
751 0	4812 418 18169	Water collector
751 1	4812 418 18171	Water guide
751 2	4812 440 18954	Fastener frame
755 0	4812 530 28785	Bend
755 2	4812 530 48148	Tray,leak
756 0	4812 360 58099	Floater
761 0	4812 480 58061	Sieve fine
761 1	4812 480 58072	Sieve insert
762 0	4812 480 58065	Microfilter
763 0	4812 480 58057	Sieve coarse
781 0	4812 530 28737	Hose,draining
781 1	4819 530 28286	Sleeve hose
781 2	4819 492 68405	Clip f.non-return valve
781 3	4812 281 28364	Flap non-return
783 0	4812 530 28792	Hose 11,5x3x200
783 4	4812 530 28793	Hose 10x3x230
783 5	4812 530 28797	Distributor
783 6	4812 530 28796	Hose 10x3x180+10
791 0	4812 532 68067	Gasket
791 2	4812 530 58093	Gasket
791 4	4812 466 68503	Gasket
791 5	4812 466 68504	Gasket
791 6	4812 466 68505	Gasket
794 1	4819 530 58032	Gasket 20x2,5
901 0	4812 401 18191	Strap 017,8
901 1	4812 401 18396	Strap
901 2	4812 401 18401	Strap
901 3	4812 401 18404	Strap 019,8-708Z
901 5	4812 401 18406	Strap 028,6-708Z
901 6	4812 401 18408	Strap 038,1-708Z
902 0	4812 401 18195	Clip
904 2	4812 462 79635	Cover WH 3,5x5
904 3	4812 462 79636	Cover WH 3,5x4
910 0	4812 502 18384	Screw 4x35-H
910 1	4812 502 18019	Screw
910 2	4812 502 18363	Screw 4,0x12-H
910 3	4812 502 18364	Screw 5x20-TORX
910 4	4812 502 18386	Screw 3,5x8-TORX T15
910 5	4812 502 18367	Screw 3,5x8-TORX T15
910 6	4812 502 18369	Screw A2F M4x6
910 7	4812 502 38132	Screw DIN 965
964 0	4812 466 68536	Gasket housing ri/le
964 1	4812 466 68469	Gasket housing upper
993 0	4812 530 48149	Bow
993 5	4822 532 80216	Funnel salt

Exploded view

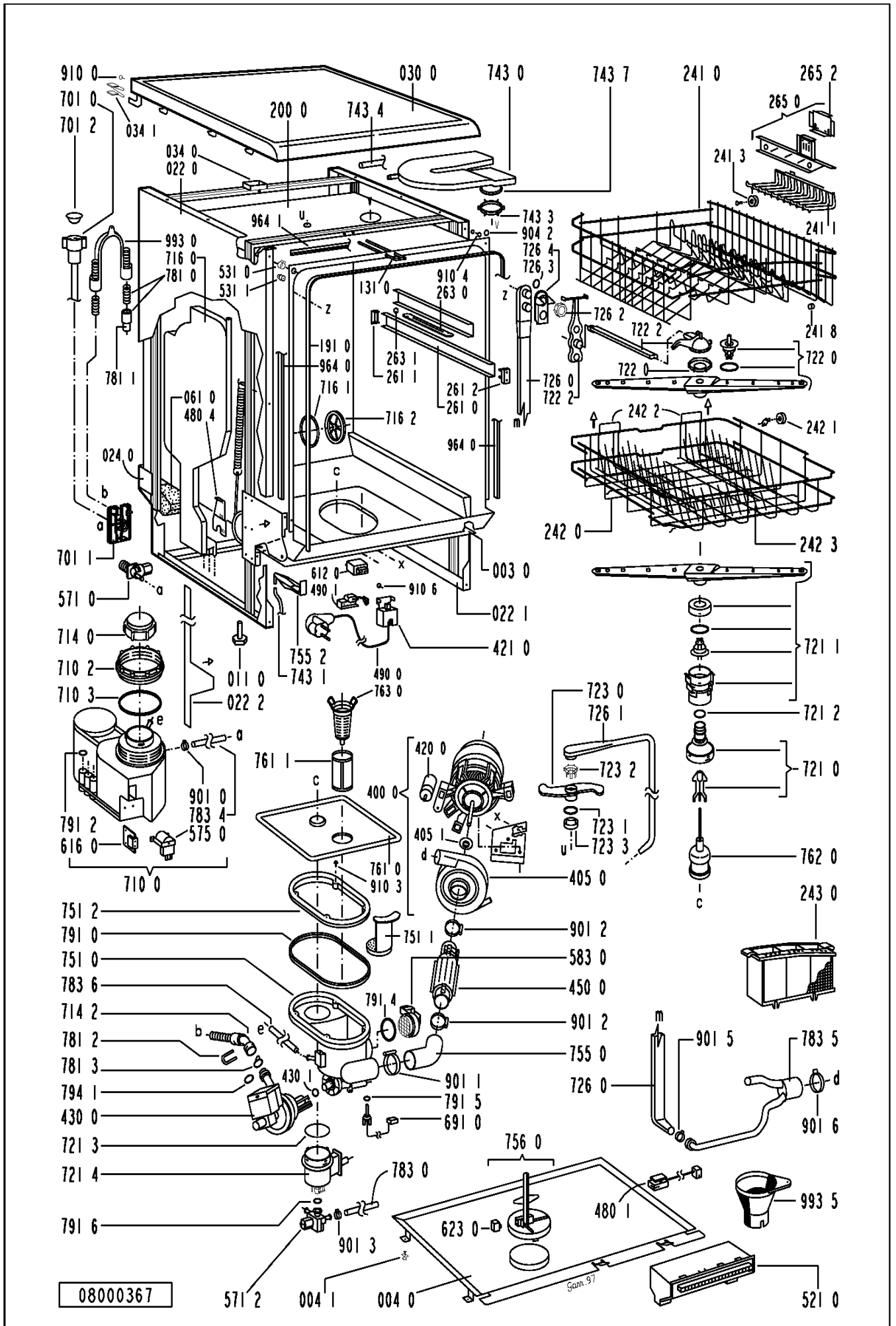

Exploded view

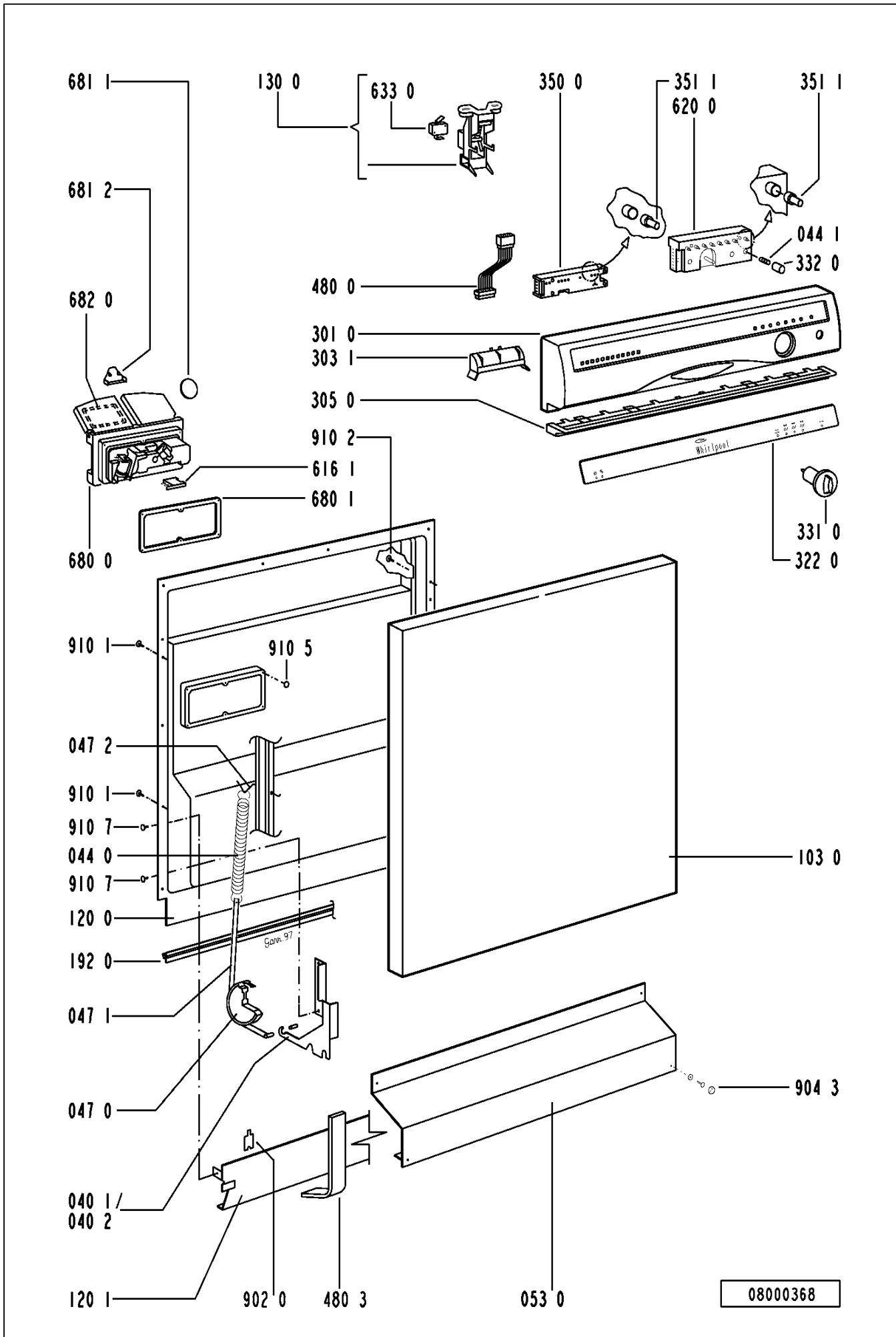

08000368

Circuit diagram

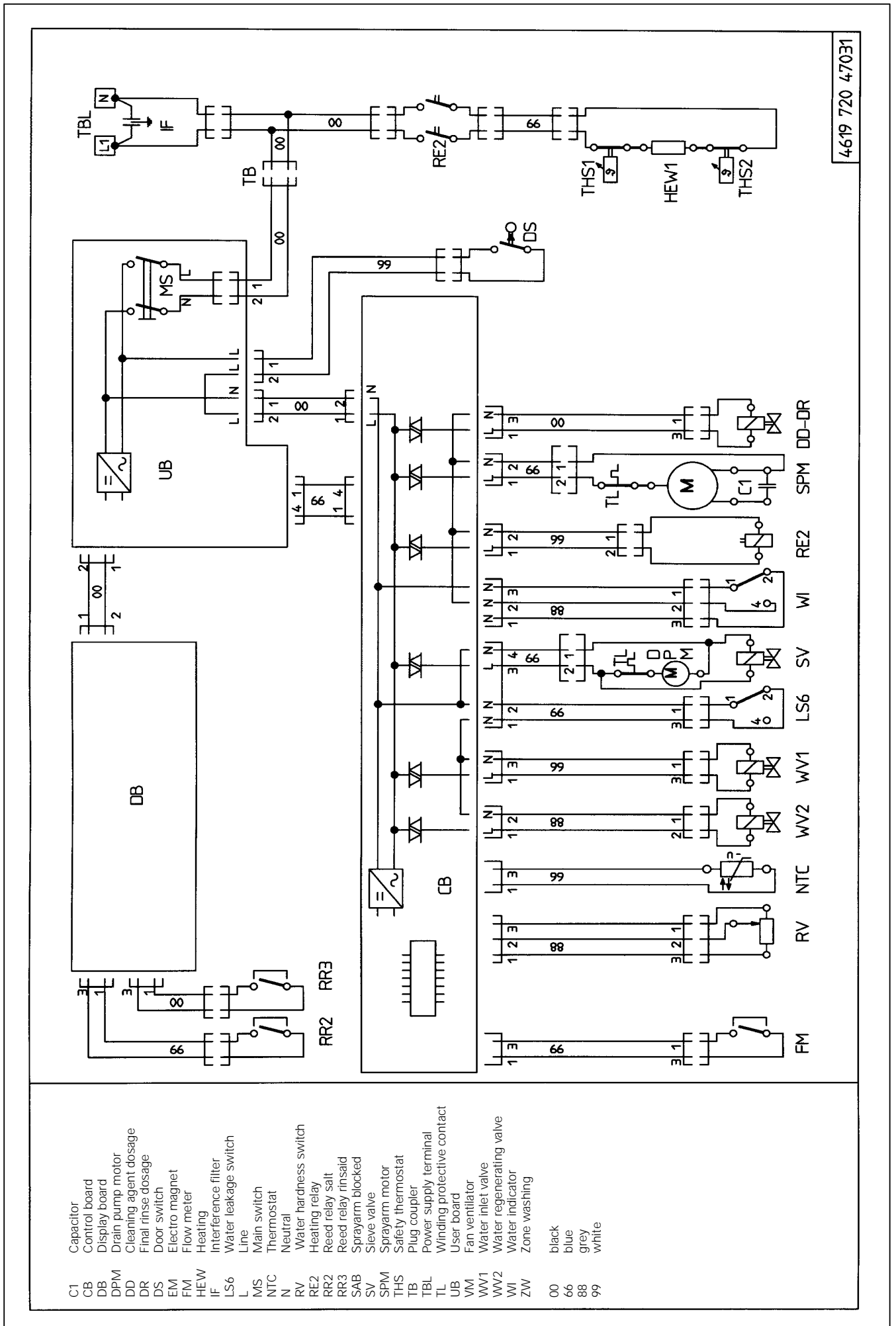

- | | |
|-----|----------------------------|
| C1 | Capacitor |
| CB | Control board |
| DB | Display board |
| DPM | Drain pump motor |
| DD | Cleaning agent dosage |
| DR | Final rinse dosage |
| DS | Door switch |
| EM | Electro magnet |
| FM | Flow meter |
| HEW | Heating |
| IF | Interference filter |
| LS6 | Water leakage switch |
| L | Line |
| MS | Main switch |
| NTC | Thermostat |
| N | Neutral |
| RV | Water hardness switch |
| RE2 | Heating relay |
| RR2 | Reed relay salt |
| RR3 | Reed relay rinsaid |
| SAB | Sprayarm blocked |
| SV | Sieve valve |
| SPM | Sprayarm motor |
| THS | Safety thermostat |
| TB | Plug coupler |
| TBL | Power supply terminal |
| TL | Winding protective contact |
| UB | User board |
| VM | Fan ventilator |
| WV1 | Water inlet valve |
| WV2 | Water regenerating valve |
| WI | Water indicator |
| ZW | Zone washing |
-
- | | |
|----|-------|
| 00 | black |
| 66 | blue |
| 88 | grey |
| 99 | white |

Text/Legend

Test procedure for SERVICE-TEST-PROGRAM DOLPHIN dishwashers

1. Start the test program.
If there is a defective component indicated, open the plinth and take out the control board.
2. Check the component.
Unplug the indicated component from the control board and check it by using an Ohm-measure equipment.
If the ohms are correct, check the cables to the component and check the component itself.
3. Check the control board.
4. Only if there is no reaction when pushing a push button or turning the rotary switch, then test with the test points.
5. At the end of the repair start the test program again to see that the failure is solved.

More details: s. chapter test program for service.

Attention:

First unplug the appliance, then set the connection clamps of the volt measurement on the test points.

Danger for short circuit.

More details see chapter test point.

Short circuits on components can damage the control board.

If electronic boards are wet, do not switch the appliance on.

The failures F1 NTC break
 F2 water leakage
 F9 continuous water inlet

are checked and indicated immediately after start of the program.

Therefore these failures have to be solved before starting the test program.

When these failures are not solved, the test program does not run.

The electrical components get their voltage via triac from the control board. For testing the volume of voltage the volt meter must be parallel to the component (the component must be plugged on). If the component is plugged off, then on the plug the measured voltage is reduced.

Text/Legend

Indication of failure and alarms

Whirlpool and Ignis appliances and also Bauknecht Flat panel appliances

failure	failure no.	indication	indication within test program
NTC - break	F1	start LED flashes	PS1 flashes
water leakage failure	F2	start LED flashes	PS2 flashes
heating system failure	F3	start LED flashes	PS3 flashes
draining failure	F4	start LED flashes	PS4 flashes
spray arm blocked	F5	PS1 flashes	PS1 + PS4 flash
water tap closed	F6	start LED flashes	PS2 + PS4 flash
flow meter failure	F7	start LED flashes	PS3 + PS4 flash
water level failure	F8	start LED flashes	PS2 + PS3 flash
water inlet continuously on	F9	start LED flashes	PS1 + PS3 flash
salt		alarm LED on	alarm LED on
rinse agent		alarm LED on	alarm LED on

Passive test program

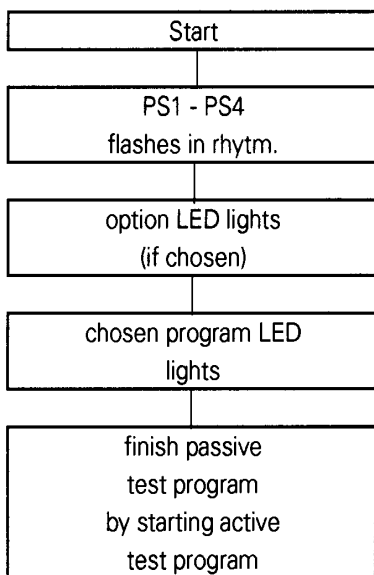

The passive test program shows the stored failure.
If there is no failure the passive test program runs normal.

Start procedure

1. Switch off the appliance
2. Push start button and hold it and select program BIO-ECO 50 °C (d) or Rapid (c)
3. Finish pushing the start button when the start LED flashes
4. Failure indication

Program sequence LED

PS1	1. LED	backrinsing prewash
PS2	2. LED	mainwash intermediate rinse final rinse
PS3	3. LED	drying
PS4	4. LED end	goes off if any button is pushed
		goes off after 30 min. progr. is finished

Text/Legend

Indication of failure and alarms

Bauknecht appliances low and high version

failure	failure no.	indication without digits	indication with digits	indication within test program
NTC - break	F1	start LED flashes	F1 at digits	PS1 flashes F1 at digits
water leakage failure	F2	start LED flashes and alarm LED	alarm LED flashes	PS2 flashes F2 at digits
heating system failure	F3	start LED flashes	F3 at digits	PS3 flashes F3 at digits
draining failure	F4	start LED flashes	F4 at digits	PS4 flashes F4 at digits
spray arm blocked	F5	PS1 flashes	alarm LED flashes	PS1 + PS4 flash F5 at digits
water tap closed	F6	start LED flashes	alarm LED flashes	PS2 + PS4 flash F6 at digits
flow meter failure	F7	start LED flashes	F7 at digits	PS3 + PS4 flash F7 at digits
water level failure	F8	start LED flashes	F8 at digits	PS2 + PS3 flash F8 at digits
water inlet continuously on	F9	start LED flashes	alarm LED flashes (water leakage)	PS1 + PS3 flash F2 at digits
salt		alarm LED on	alarm LED on	alarm LED on
rinse agent		alarm LED on	alarm LED on	alarm LED on

With the passive test program all LEDs and buttons can be tested.

Passive test program

If there is no failure, the passive test program runs normal.

Start procedure

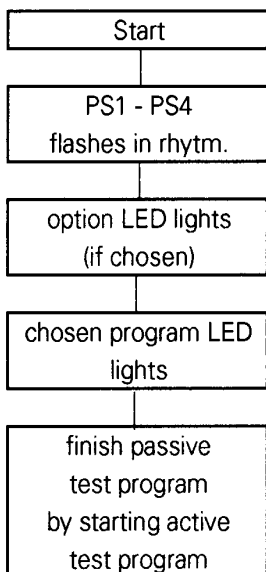

ROTARY VERSION

1. Switch off the appliance
2. Select program BIO/ECO (d)
3. Push start button and hold it and switch on the main switch
4. When start LED flashes, then release start button

PUSH BUTTON VERSION

1. Switch off the appliance
2. Push start button hold it and switch on the main switch
3. Release the start button when the start LED flashes
4. Select program BIO/ECO (d)

Program sequence LED

PS1	1. LED	backrinsing prewash	
PS2	2. LED	main wash intermediate rinse final rinse	
PS3	3. LED	drying	
PS4	4. LED end	goes off if any button is pushed	goes off after 30 min. progr. is fin.

Text/Legend

Active test program

All appliances Bauknecht, Whirlpool and Ignis

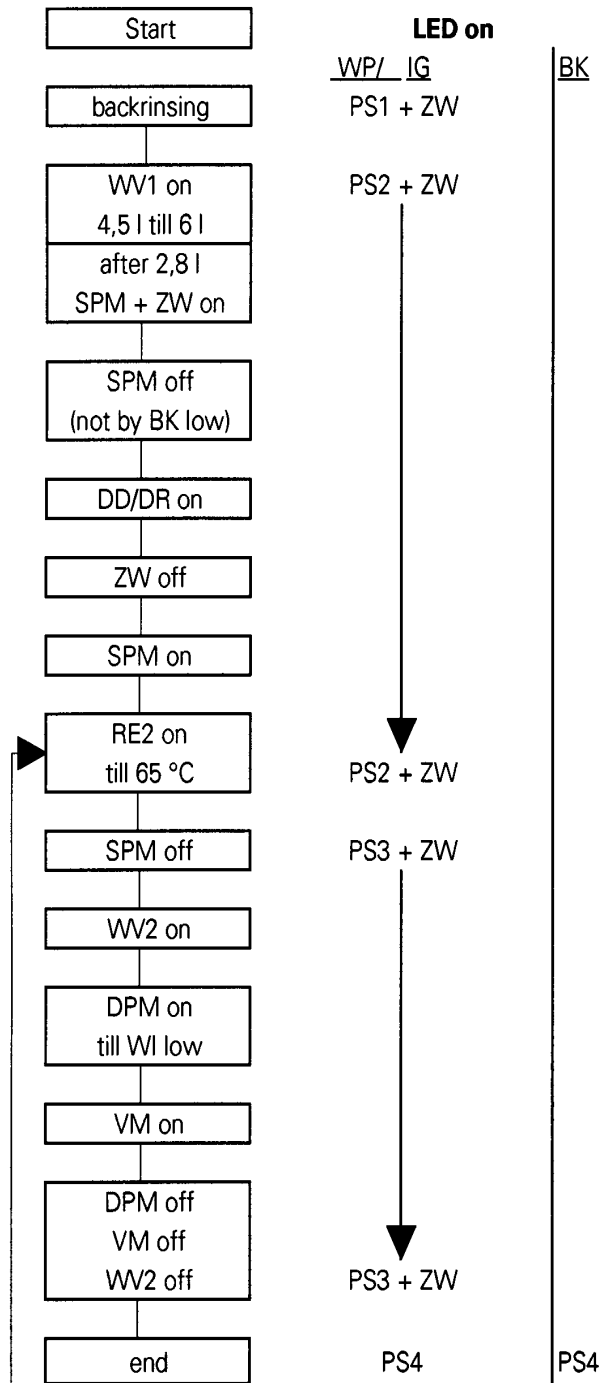

Test procedure
 1. passive test program O. K.?
 no: repair failure
 yes: push start button shorter than 3 sec.
 2. active test program starts

Remarks
 The active test program runs to the failure position and stops or, if there is no failure, to the end.
 To leave the test progr. push start button for longer than 3 sec.
 Too less salt or too less rinse aid leads not to the stop of the appliance.
 The function of the zone wash valve can only be checked optically.
 A defect leads to an instable SPM pressure.
 The function of the sieve valve can only be checked optically.
 In case of defect the housing of the selfcleaning microfilter is not empty on the end of the program.

only on this step can be jumped to the next step by short pushing the start button again

Appliances which have no program sequence LED/digits cannot show the failure.
 On these appliances the failure can only be found by starting the test program and following this by using the program chart.
 The steps of the test program are as normal.

The failure position is indicated:
 On WP and IG appliances by switching off the flashing start LED.
 On BK appliances the flashing start LED lights continuously.

Text/Legend

Handling of failures

F1. NTC break

- temperature out of the normal value (-10 degr. till +85 degr. C)

Possible failures

- heating higher than +85 degr. C
- NTC defective
- dishwasher is frozen, less than -10 degr. C

F2. water leakage

- water is in the drip tray
floater (LS6) switches off the WV1 and the electronic switches on the DPM till WI reports empty

F3. heating system defective

- too less heating speed (lower 1,5 degr. in 20 min.)
- heating (HEW) defective
- relais (RE2) defective

F4. draining failure

- drain pump starts and after 4 min. the WI detects not empty
- drain pump (DPM) defective
- syphon closed
- control board (CB) defective
- water indicator (WI) defective (is switched on)

F5. spray arm blocked (leads not to stop the appliance)

- SAB sensor sends less than 10 impulses/min.
- spray arm blocked or not fixed well
- selfcleaning microfilter blocked
- spray pump (SPM) does not work well
- SAB sensor defective

Text/Legend

F6. water tap closed

water valve (WV1) is switched on but flow meter (FM) sends no impulses (less than 10 imp. in 10 sec.) and the water indicator (WI) is at low level

- water tap closed
- water inlet hose blocked
- water inlet valve (WV1) defective
- flow meter (FM) defective (leads to FM failure)

F7. flow meter failure

water inlet valve is switched on and the water indicator (WI) is switched on high level

- flow meter (FM) sends to less impulses (less than 10 imp. in 10 sec.)
- water tap closed
- water inlet hose blocked
- water inlet valve (WV1) defective
- flow meter (FM) defective
- water indicator (WI) is defective

F8. water level failure

failure monitored during spray pump is on and the water indicator switches back more than 10 times in 2 min.

- water indicator defective
- sieve blocked
- water strongly foams
- pot has turned off and is filled with spray water
- no stable spray pump (SPM) working

F9. continuous water inlet

water inlet valve (WV1) is switched off, water indicator (WI) on, flow meter (FM) sends impulses more than 10 imp. in 10 sec.

- water inlet valve (WV1) mechanically not closed
- triac (CB) for WV1 is closed

reaction: interval 30 sec. draining / 20 sec. tracing

For salt, rinse aid, zone wash valve, sieve valve failure see active test program.

Text/Legend

			Programs												
BK	IG	WH	a	b	c	d BK	d WI	e BK	e WI	f	g	h	i	j	k
A3			X			X				X					
	A3	A3	X		X		⊗			X					
A4			X			X		X		X					
	A4	A4	X		X		⊗		X	X					
	A5	A5	X		X		⊗		X	X	X				
	A6	A6	X		X		X		X	X	X				
	A7		X	X	X		X		X	X	X				
B4			X			X		X		X					
B5			X			X		X		X	X				
		B5	X		X				X	X	X				
B6			X		X	X		X		X	X				
		B6	X		X		X		X	X	X				
		B7	X	X	X		X		X	X	X				
C5			X			X		X		X	X				
C6			X		X	X		X		X	X				
C7			X	X	X	X		X		X	X				
C11			X	X	X	X		X		X	X	X	X	X	X

⊗ only for IG instead of program c

- a prewash
- b glass 40°C
- c rapid 50°C
- d bio/eco 50°C (BK without prewash, WH-IG with cold prewash)
- e bio/normal 50°C BK (with cold prewash)
- e daily 65°C (only WH-IG without prewash)
- f normal 65°C (with cold prewash)
- g intensive 70°C (with prewash 40°C)
- h -d- bio/eco 50°C (BK without prewash) + e-button
- i -e- bio/normal 50°C BK (with cold prewash) + e-button
- j -f- normal 65°C (with cold prewash) + e-button
- k -g- intensive 70°C (with prewash 40°C) + e-button

After starting a program this program is locked. That means neither by unplugging/switching of the appliance nor by setting an other program, the first setted program can be changed. Chancing of the program is only possible by pushing the start button again for longer than 3 sec..

On appliances with seperate On-Off button the last used program is stored. That means if the customer wants to use the same program again he has only to press the On-button and the Start-button.

Text/Legend

Test points on the control board for Whirlpool and Ignis appliances

With these test points the function of the buttons and the rotary switch can be checked. The test points are in the service window on the control board.

For the test fine clamps, cables and volt meter with high input resistance are necessary.

Before setting the clamps on the test points, switch off the appliance.

Test points: T0 = common line T2 = analogue value
 T1 = analogue value T3 = digital signal

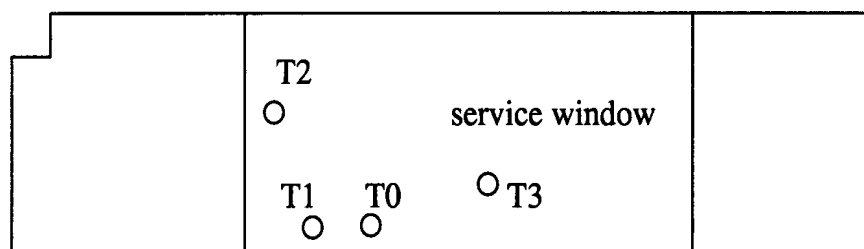

control board

Check: test point T0 to T1

Communication between Control board and Display board

pushed button	voltage	from	to
all off	appr. -6,19 V (DC)	control board	display board
ZW	appr. -3,69 V (DC)	display board	control board
delay start	appr. -2,33 V (DC)	display board	control board
ZW + delay start	appr. -1,85 V (DC)	display board	control board

Check: test point T0 to T2

Communication between Control board and User board

rotary switch	voltage	from	to
progr. a	appr. -1,54 V (DC)	user board	control board
progr. b	appr. -2,06 V (DC)	user board	control board
progr. c	appr. -2,57 V (DC)	user board	control board
progr. d	appr. -3,42 V (DC)	user board	control board
progr. e	appr. -3,96 V (DC)	user board	control board
progr. f	appr. -4,47 V (DC)	user board	control board
progr. g	appr. -5,00 V (DC)	user board	control board
start button	appr. 0,00 V (DC)	user board	control board

Check: test point T0 to T3

Communication between Control board and Display Board

multiplexing appr. -3,18 V (DC)

How exact the data are, depends on the measure equipment.

Text/Legend

Test points on the control board for Bauknecht appliances

With these test points the function of the buttons and the rotary switch can be checked. The test points are in the service window on the control board.

For the test fine clamps, cables and volt meter with high input resistance are necessary.

Before setting the clamps on the test points, switch off the appliance.

Test points: T0 = common line T2 = analogue value T3 high = serial link
 T3 low = digital signal

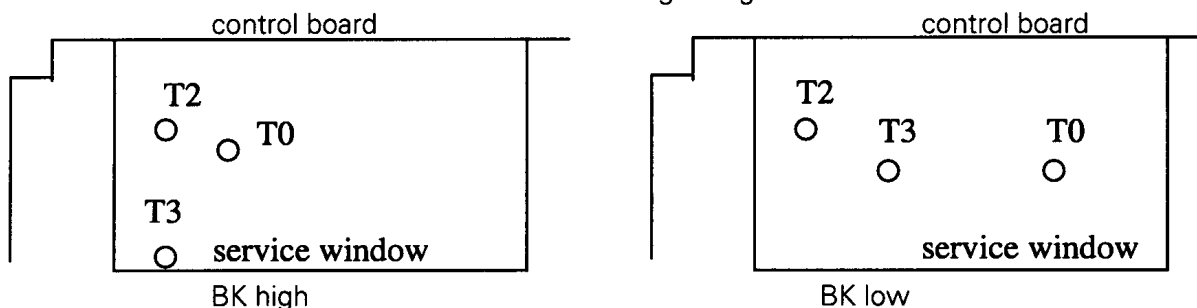

Check: test point T0 to T2 high range (see control board: BK-CB -H)

Communication between Control board and User board or Control- and Display board

pushed button or rotary switch	voltage	from	to
off	appr. -5,0 V (DC)	control board	user board
progr. a	appr. -1,0 V (DC)	user board	control board
progr. b	appr. -1,5 V (DC)	user board	control board
progr. c	appr. -2,0 V (DC)	user board	control board
progr. d (h)	appr. -2,5 V (DC)	user board	control board
progr. e (i)	appr. -3,0 V (DC)	user board	control board
progr. f (j)	appr. -3,5 V (DC)	user board	control board
progr. g (k)	appr. -4,0 V (DC)	user board	control board
start button	appr. -0,6 V (DC)	user board	control board
option- , gentle- or delay button	appr. -5,0 V (DC)	control board	display board

Check: test point T0 to T2 low range (see control board: BK-CB -L)

Communication between Control board and User board or Control- and Display board

pushed button or rotary switch	voltage	from	to
off	appr. -5,0 V (DC)	control board	user board
progr. a	appr. -1,0 V (DC)	user board	control board
progr. b	do not exist on low range		
progr. c	appr. -1,5 V (DC)	user board	control board
progr. d	appr. -2,0 V (DC)	user board	control board
progr. e	appr. -2,5 V (DC)	user board	control board
progr. f	appr. -3,0 V (DC)	user board	control board
progr. g	appr. -3,5 V (DC)	user board	control board
start button	appr. -0,6 V (DC)	user board	control board
eco-dry button	appr. -4,0 V (DC)	control board	display board
delay button	appr. -4,5 V (DC)	control board	display board

Check: test point T0 to T3 high range

no program running	-0,8/-1,0 V (DC)	control board	display board
program bio/eco running	-0,3/-0,8 V (DC)	control board	display board

Check: test point T0 to T3 low range

multiplex signal	-2,5 V (DC)	control board	display board
------------------	-------------	---------------	---------------

How exact the data are, depends on the measure equipment.